



KAMELEON DETECTION 7W



FICHE TECHNIQUE



► CARACTERISTIQUES TECHNIQUES GENERALES

REFERENCE	KAMELEON DETECTION 7W 3CCT
CODE PRODUIT	704343 (BLANC MAT RAL9016)
CODE ACCESSOIRE COLLERETTE NOIRE	704344 (NOIR MAT)
CODE ACCESSOIRE COLLERETTE ALU BROSSE	704348 (ALU BROSSE)
TYPE DE SOURCE	LED
DETECTEUR DE PRESENCE	MODE MAITRE INTEGRE AVEC SORTIE COMMUTEE - PEUT CONTROLER 200W MAX
MODE D'INSTALLATION	ENCASTRE
INDICE DE PROTECTION	IP 65 (AUTORISE VOLUME I ET II)
INDICE DE RESISTANCE AUX CHOCS	IK 04
HAUTEUR	39 MM
DIAMETRE ENCASTREMENT	69 MM
DIAMETRE EXTERIEUR	90 MM
TEMPERATURE DE FONCTIONNEMENT	- 20 °C / + 50 °C
POIDS PRODUITS	0.25 KG
MATERIAU CORPS/DIFFUSEUR	ALUMINIUM / POLYCARBONATE
RE2020 (ETANCHE EAU, AIR, RECOUVRABLE TOUT ISOLANT - SOUFFLE ET DEROULE)	CONFORME

► CARACTERISTIQUES PHOTOMETRIQUES ET PERFORMANCE

PUISSANCE	7 W
FLUX LUMINEUX SORTANT	720 LM (4000K) 750 LM (3000K) 660 LM (2700K)
EFFICACITE LUMINEUSE 3000K/4000K	> 100 LM/W
TEMPERATURE DE COULEUR REGLABLE VIA INTERRUPTEUR (FACE AVANT SPOT)	2700K / 3000K / 4000K
IRC	> 85
ANGLE D'OUVERTURE DU FAISCEAU LUMINEUX	60°
EMISSION DE LUMIERE	DIRECT/SYMETRIQUE
DIFFUSEUR	LENTILLE POLYCARBONATE
CHROMACITE INITIALE - ELLIPSE DE MCADAM	SDCM < 4



**DETECTEUR
INFRAROUGE
Mode Maître
Intégré**



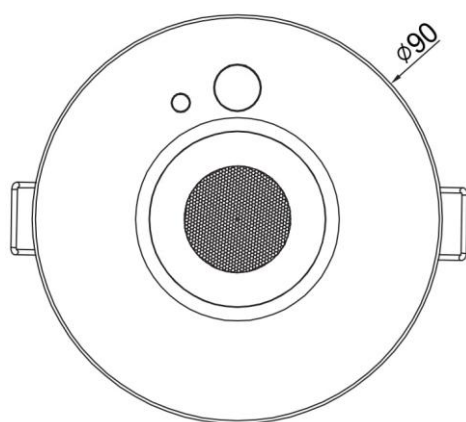
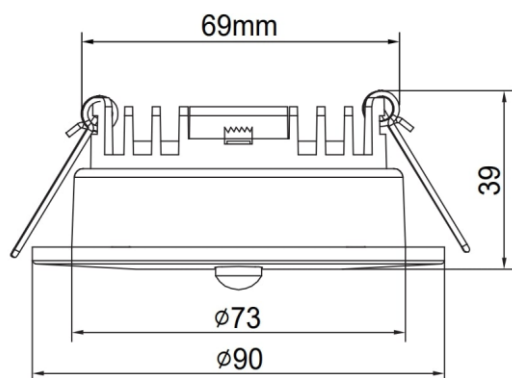

▶ CARACTERISTIQUES ELECTRIQUES

DETECTEUR DE PRESENCE INTEGRE	OUI (INFRAROUGE) MODE MAITRE INTEGRE AVEC SORTIE COMMUTEE - PEUT CONTROLLER 200W MAX
REGLAGE DE LA LUMINOSITE	DE 0 A 3000 LUX
REGLAGE DE LA SENSIBILITE	DE 0 A 100%
REGLAGE DE LA TEMPORISATION	DE 15 SECONDES A 30 MINUTES
HAUTEUR D'INSTALLATION CONSEILLEE	2,8 A 3 METRES
AIRE DE DETECTION AU SOL MAXIMUM	6 METRES
DRIVER INCLUS	OUI RECOUVRABLE TOUT ISOLANT SOUFFLE/DEROULE
DIMMABLE	OUI
TYPE DE GRADATION	DIMMABLE TRIAC
CLASSE ELECTRIQUE	III (AUTORISE VOLUME I ET II SALLE EAU)
TENSION / FREQUENCE ENTREE	220-240 V / 50-60 Hz
CONNEXION	BORNIER 6 POLES
CONSOMMATION ELECTRIQUE	7 Watts
AMPERAGE SORTIE DRIVER	230-250 mA
TENSION SORTIE DRIVER	22-26 Vdc / Facteur de puissance > 0,9

▶ DONNEES NORMATIVES ET LOGISTIQUES

GARANTIE	5 ANS
DUREE DE VIE DU PRODUIT	50 000 HEURES
MAINTIEN DU FLUX - LM80	L80B10 > 50 000 HEURES (Ta : 25°C)
ESSAI AU FIL INCANDESCENT	850 °C
RISQUE PHOTOBIOLOGIQUE (EN 62471)	0
UNITE D'EMBALLAGE	1 PIECE
CONDITIONNEMENT PAR CARTON	40 PIECES PAR CARTON
MARQUAGE CE et ROHS	OUI

